

SILENT PILER

ZP150

CARACTERISTIQUES	SPECIFICATION	SPZIFIKATION	
Silent Piler	Silent Piler	Silent Piler	
Modèle de Palplanches	Sheet Pile Range	Stahlsplundbohle	AZ18, AZ26, AZ36 FX18, FX26, FX36
Force d'Enfoncement Force d'Arrachage	Installation Force Extraction Force	Einpreßkraft Ziehkraft	150 t 160 t
Course	Stroke	Hub	800 mm
Vitesse d'Enfoncement Vitesse d'Arrachage	Pressing-in Speed Drawing-out Speed	Preßgeschwindigkeit Ziehgeschwindigkeit	1,4 - 22,7 m/min 2,2 - 17,6 m/min
Commande Radio	Radio Control	Funkfernbedienung	○
Autonome	Self-Moving	Selbstbewegend	○
Longueur Largeur Hauteur Hauteur Maximum	Machine Lenght Machine Width Machine Height Max Height	Maschinenlänge Maschinenbreite Maschinenhöhe Maximale Höhe	3 380 mm 1 300 mm 2 765 mm 3 425 mm
Poids	Weight	Gewicht	13 200 kg

Groupe	Power Pack	Aggregat	
Modèle du Groupe	Unit Type	Antrieb Typ	EU 200
Groupe Moteur	Power Source	Stromquelle	Diesel Engine 150 kW / 200 HP
Réservoir d'Essence Huile Hydraulique	Fuel Tank Hydraulic Oil	Dieseltank Hydraulische Öl	350 litres 550 litres
Niveau Sonore à 7 m (Circa)	Noise Level @ 7 m (Average)	Lärmpegel bei 7 m (Durchschnittlich)	69 dB(A)
Longueur Largeur Hauteur	Length Width Height	Länge Breite Höhe	4 040 mm 1 555 mm 1 780 mm
Poids	Weight	Gewicht	4 500 kg

Chassis de Demarrage	Reaction Stand	Startvorrichtung	
Longueur (Longueur Maximum)	Lenght (Max Lenght)	Länge (Maximale Länge)	3 880 mm (7 220 mm)
Largeur (Largeur Maximum)	Width (Max Width)	Breite (Maximale Breite)	2 200 mm (5 650 mm)
Hauteur	Height	Höhe	527 mm
Poids	Weight	Gewicht	2 100 kg

*Les caractéristiques techniques sont susceptibles d'être modifiées sans avertissement.

*Specifications are subject to alteration without prior notice.

*Technische Änderungen vorbehalten.

GIKEN EUROPE B.V.

HEAD OFFICE (NL)

Tel: +31 (0)36 532 8128

Fax: +31 (0)36 532 7477

Damsluisweg 13, 1332 EA Almere - De Vaart, The Netherlands

LONDON OFFICE (GB)

Tel: +44 (0)171 488 0073

Fax: +44 (0)171 488 0072

Suite 10, International House, 1 St. Katharine's Way, London E1 9UN, U.K.

BERLIN OFFICE (D)

Tel: +49 (0)30 2092 4137 / 4139

Fax: +49 (0)30 2092 4138

Lindencorso, Unter den Linden 21, 10117 Berlin, Germany

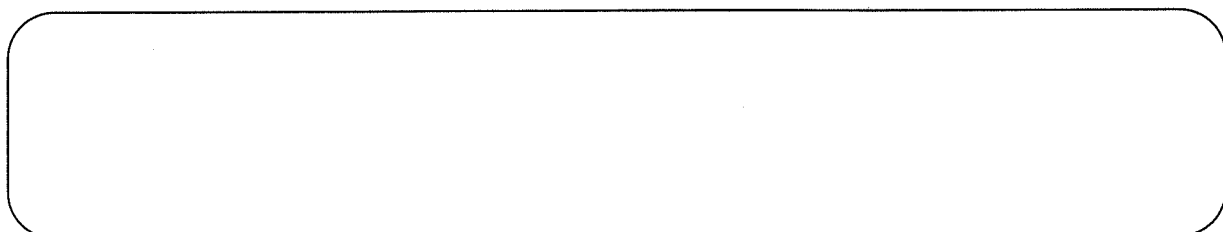

Z-PILER

ZP150

SMP Method - No Noise No Vibration

Hydraulic Pile Jacking System

Einpreßung von Z-Profilen

**AZ18, AZ26, AZ36
FX18, FX26, FX36**

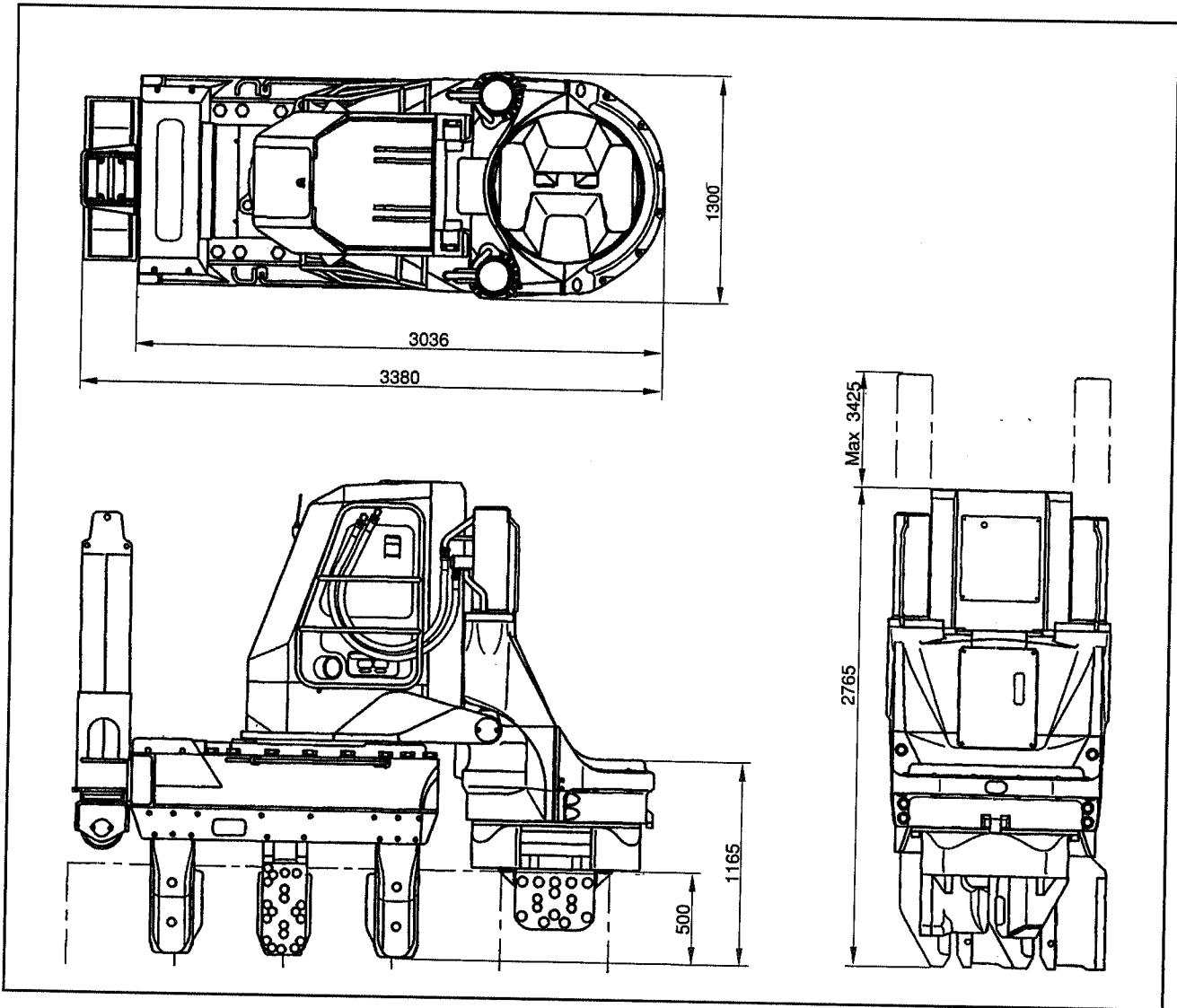

Sheet Pile Range (Z-profile)	Stahlspundbohle (Z-Profil)	AZ18, AZ26, AZ36 FX18, FX26, FX36
Installation Force	Einpreßkraft	150 t
Pressing-in Speed	Preßgeschwindigkeit	1,4 - 22,7 m/min
Machine Weight	Gewicht	13 200 kg
Power Pack (Diesel Engine)	Aggregat (Dieselaggregat)	EU 200 150 kW / 200 HP

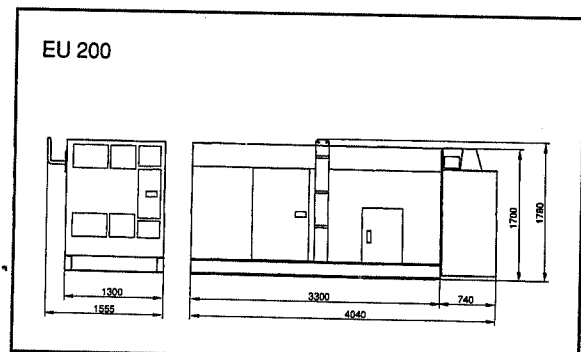

GIKEN